

SPECIFICATION FOR APPROVAL

REF. :

PROD. NAME	SMD Line Filter	ABC'S DWG NO.	SF0504□□□□L□-□□□		
		REV.	20150629-I	PAGE	1

I . Configuration and dimensions :

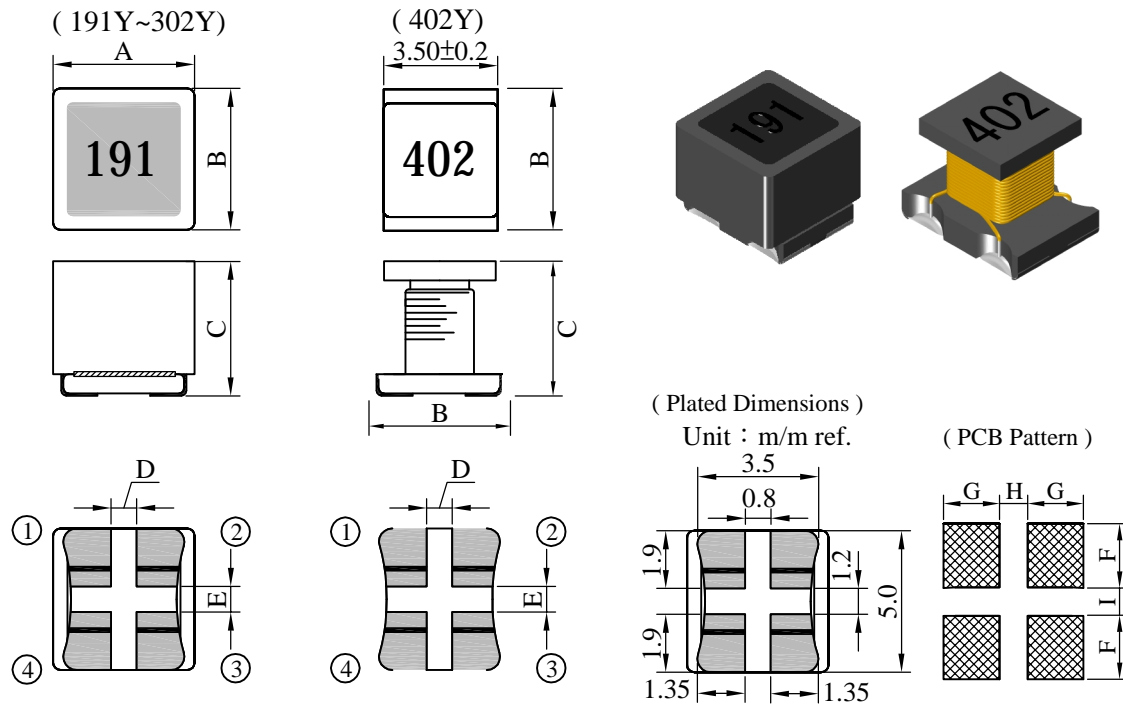

Unit : m/m

A	B	C (191Y~351Y)	C (102Y~402Y)	D	E	F	G	H	I
4.80 ± 0.2	5.00 ± 0.2	4.80 max.	4.70 max.	0.80 typ.	1.20 typ.	2.30 ref.	1.60 ref.	0.80 ref.	1.00 ref.

II . Schematic diagram :

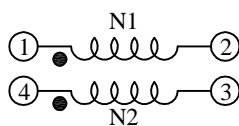

III . Description :

- a . Ferrite drum core construction.
- b . Enamelled copper wire : H class
- c . Product weight : 0.35g (ref.)
- d . Moisture sensitivity Level 1
- e . Products comply with RoHS' requirements
- f . Halogen free available

IV . General specification :

- a . Storage Temp. : -40°C ---- $+125^{\circ}\text{C}$
- b . Operating Temp. : -40°C ---- $+125^{\circ}\text{C}$
(Temp. rise included)
- c . Resistance to solder heat : 250°C .10 secs.

Peak Temp : 250°C max.
 Max. Peak Temp - 5°C : 30sec max.
 Max time above 217°C : 60sec~150sec max.

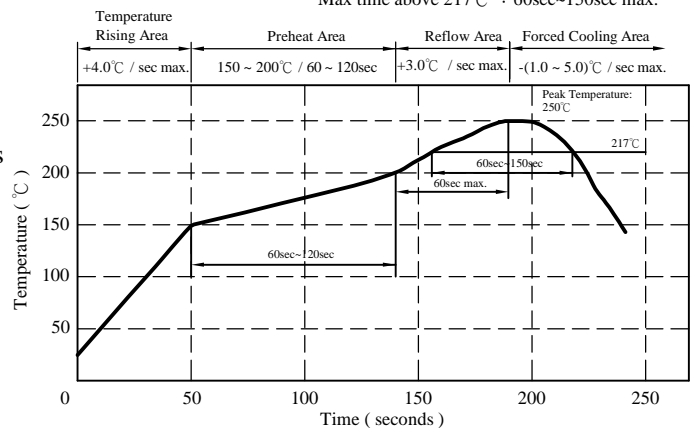

AR-001C

SPECIFICATION FOR APPROVAL

REF. :

PROD. NAME	SMD Line Filter	ABC'S DWG NO.	SF0504□□□□L□-□□□		
		REV.	20150629-I	PAGE	2

V . Electrical characteristics :

DWG No.	Common mode impedance (at 100MHz , 20 degree C) (KΩ)	Inductance (uH) ref.	IDC (mA)	RDC (max.) (mΩ)	Impedance (KΩ)	Freq. range (MHz)
SF0504191YL□-□□□	0.19 ±35%	0.60	5000	20.0	0.1 min.	100 ~ 700
SF0504351YL□-□□□	0.35 ±35%	1.10	2000	40.0	0.2 min.	90 ~ 400
SF0504102YL□-□□□	1.00 ±35%	2.70	1500	60.0	0.4 min.	50 ~ 300
SF0504152YL□-□□□	1.50 ±35%	3.60	1000	100.0	0.6 min.	40 ~ 200
SF0504302YL□-□□□	3.00 ±50%	6.00	500	200.0	0.9 min.	30 ~ 150
SF0504402YL□-□□□	4.00 ±50%	2.80	200	300.0	2.0 min.	80 ~ 160

- 1). □ : Packaging information : □ Code
- 2). "-□□□" : Reference code
- 3). Electrical specifications at 25°C
- 4). Rated voltage 50 Vdc
- 5). Withstand Voltage 125Vdc
- 6). Insulation Resistance 10MΩ min.
- 7). Inductanct test Freq. : 100kHz / 0.1V

AR-001C

SPECIFICATION FOR APPROVAL

REF. :

PROD. NAME	SMD Line Filter	ABC'S DWG NO.	SF0504□□□□L□-□□□		
		REV.	20150629-I	PAGE	3

VI . Curve :
SF0504191YLB

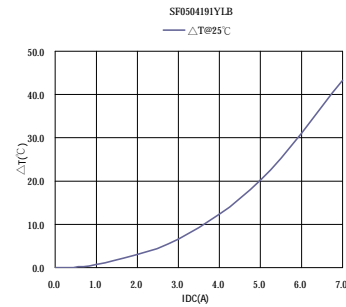
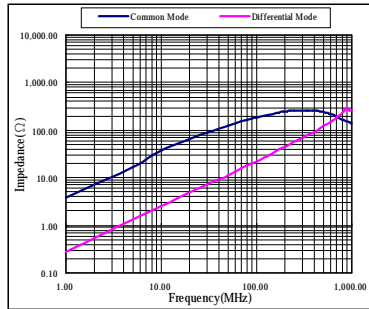

SF0504102YLB

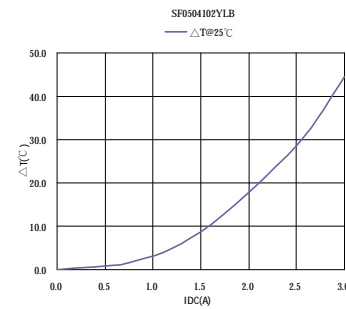
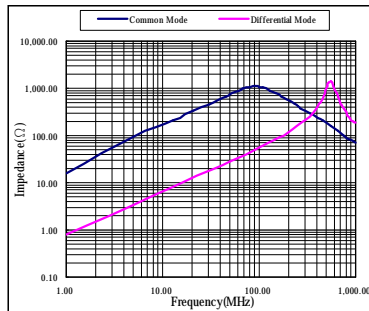

SF0504152YLB

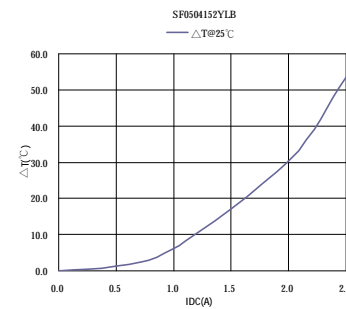
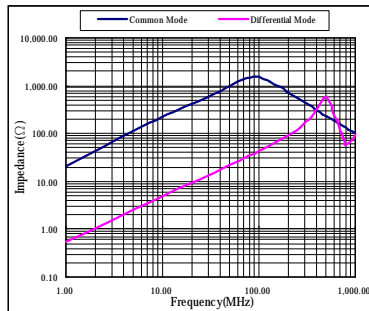

SF0504302YLB

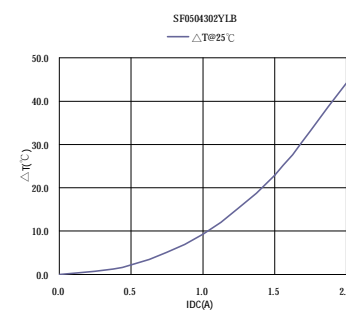
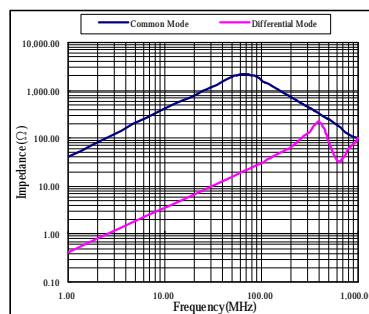

AR-001C

SPECIFICATION FOR APPROVAL

REF. :

PROD. NAME	SMD Line Filter	ABC'S DWG NO.	SF0504□□□□L□-□□□		
		REV.	20150629-I	PAGE	4

VII . Packaging information :

(1) Configuration

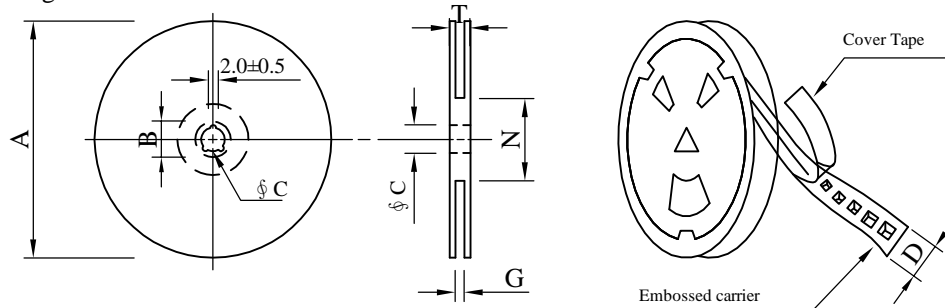

※Carrier Tape width : D

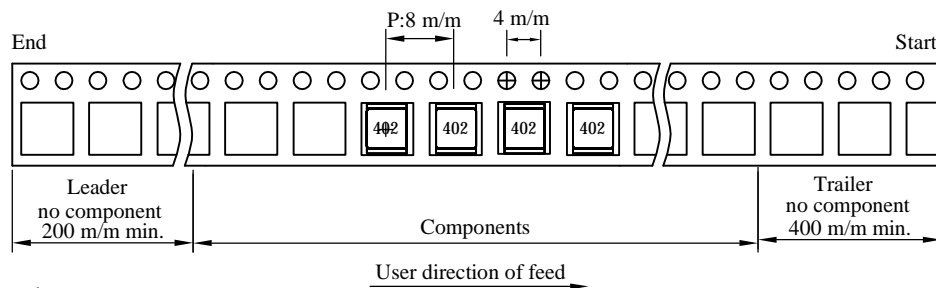
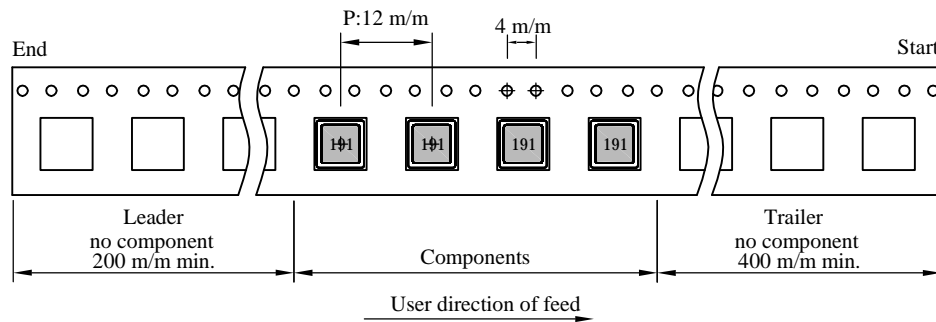

(2) Dimensions

Unit:m/m

Style	A	B	C	D	G	N	T
13 - 16	330	21±0.8	13±0.5	16	18 ⁺⁰	50 ⁻⁰	22.4

(3) Q'TY & G.W. Per package

Code	Inner : Reel			Outer : Carton		
	Q'TY (pcs)	G.W. (gw)	Style	Q'TY (pcs)	G.W. (Kg)	Size (cm)
B	1,000	760	13 - 16	6,000	5.8	38 x 37 x 22
B (For 402Y)	1,500	730	13 - 16	9,000	5.7	38 x 37 x 22
C	1,200	820	13 - 16	7,200	6.2	38 x 37 x 22

AR-001C

SPECIFICATION FOR APPROVAL

REF. :

PROD. NAME	SMD Line Filter	ABC'S DWG NO.	SF0504□□□□L□-□□□		
		REV.	20150629-I	PAGE	5

VIII . Reliability test :

Item	Reference documents	Test Condition	Test Specification
1.High Temperature Exposure	MIL-STD-202 Method 108	1.Temperature: 125±2℃ 2.Time:96±2 hours.	1.No mechanical or electrical damage. 2.Impedance shall not change more than ±50%.
2.Temperature Cycling	JESD22-A 104	1.Temperature: -40℃ ~ +125℃ 2.Number of cycle:100 cycle 3.Dwell time:30 minutes	1.No mechanical or electrical damage. 2.Impedance shall not change more than ±50%.
3.Biased Humidity Test	MIL-STD-202 Method 103	1.Temperature : 85±2 ℃ 2.Humidity: 85% RH. 3.Time:96±2 Hours	1.No mechanical or electrical damage. 2.Impedance shall not change more than ±50%.
4.Operational Life	JESD22-A 108	1.Temperature: 125℃ (Temp. rise included) 2.Time:96±2 hours. 3.Rated current	1.No mechanical or electrical damage. 2.Impedance shall not change more than ±50%.
5.External Visual	JESD22-B 101 & MIL-STD-883 Method 2009	Inspect product constructions, marking and workmanship.	1.No pollution on the surface of products. 2.Clear marking. 3.No crack.
6.Physical Dimensions	JESD22-B 100	Verify physical dimensions to the applicable product detail specification.	Per product specification standard
7.Resistance to solvents	MIL-STD-202 Method 215	Immerse into solvent for 3±0.5 minutes & brush 10 times for 3 cycles.	1.No body change in appearance. 2.No marking blurred. 3.Impedance shall not change more than ±50%.
8.Vibration Test	MIL-STD-202 Method 204	1.Frequency and Amplitud : 10-2000-10 Hz, 1.5 mm. 2.Direction:X, Y, Z 3.Test duration:2 hours for each direction, 6 hours in total.	1.No mechanical or electrical damage. 2.Impedance shall not change more than ±50%.
9.Resistance To Soldering Heat Test	MIL-STD-202 Method 210 & J-STD020D.1	1.Highest temperature : 250±5℃. 2.Time (temp. ≥ 217℃) : 60~150 Second. 3.IR reflow times : 3 times.	1.No mechanical or electrical damage. 2.Impedance shall not change more than ±50%.
10.Over load	JIS C 6436 & User SPEC.	1.Applied one and half rated current for a period of 5 minutes. 2.Rated current	No electrical or mechanical damage
11.Temperature Rise Current	JIS C 6436 & User SPEC.	1.Applied rated current for 10 minutes. 2.Temperature measure by digital surface thermometer. 3.Irms current	Surface temperature rise is less than 40℃ typ.
12.Solderability Test	J-STD-002 & JESD22-B 102	1.Baking in pre-testing : 150±5℃ / 16Hours±30 min. 2.Peak temperature : 240±5℃ 3.Time (temp. ≥ 217℃) : 60~150 second. 4.IR reflow times : 1 times.	More than 95% soldering coverage min on terminations.
13.Electrical Characteriazation	MIL-STD-202 Method 304 & User SPEC.	1.Operating temperature : -40℃~125℃ 2.Room temperature : 25℃.	1.No mechanical or electrical damage. 2.Impedance shall not change more than ±50%.
14.Withstanding Voltage Test	MIL-STD-202 Method 301 & User SPEC.	1.DC: 125 V (Winding to Winding) 2.Time : 1minutes	1.During the test no breakdown. 2.No mechanical or electrical damage.
15.Drop	CNS-C6354 & GB/T 2423.8	1.Products shall be mounted on SPEC. PCB and dropped down from a height of 1m 2.Drop total time : 6 time (Every side of sample drop 2 time)	1. Adhesion on PCB shall be enough. 2. Product appearance shall not break. 3. No electrical damage.
16.Terminal Strength Test	IEC 60068-2-21	1.Apply push force to samples mounted on PCB. 2.Force of 1.8 kg for 60±1 seconds.	After test, inductors shall be no mechanical damage.

AR-001C